

G 1/8 - 3/2 Midget Poppet Valves

- Light weight and compact 3/2 poppet design.
- Plunger operated, roller operated and one way trip lever operated can be used as limit switch in machine tool application.
- Lock down lever operated and push button operated valves are useful for operating single acting actuators.

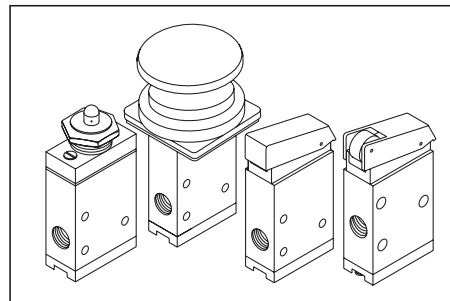

PART LIST

NO.	DESCRIPTION	QTY.
1	Body	1
2	Housing	1
3	Cap	1
4	Plunger	1
5	Ball	1
6	'O' Ring	1
7	Shell	1
8	Spring	2
9	U Cap seal	1
10	Bush	1
11	'O' ring	1
12	Spacer	1

Seal kit consists of item No. 6, 7, 9 & 11.

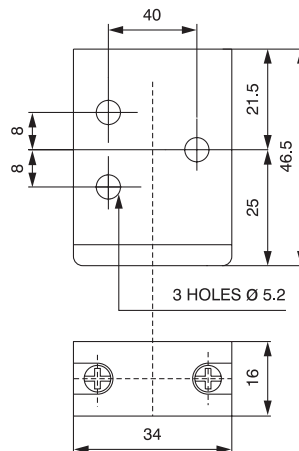
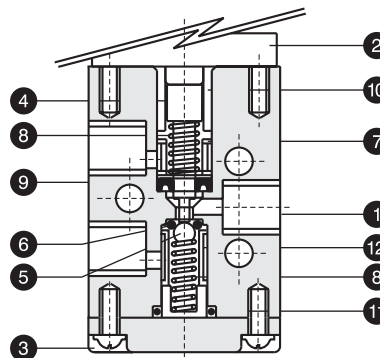

SPECIFICATIONS

Pressure range	0-10 bar air
Flow rate	175 Lit/min @ 7 bar
Cv factor	0.175
Maximum temperature	85° C
Plunger travel	4.2 mm

3/2 PLUNGER OPERATED VALVE

(Part No. N 53603C)

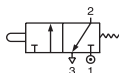

This valve can be mechanically or manually operated & is provided with a threaded neck & hex nut as standard, for ease of mounting. When used for mechanical actuation it is designed for in-line actuation only. Max. travel : 4.2 mm Do not exceed travel as it can damage the mechanism.

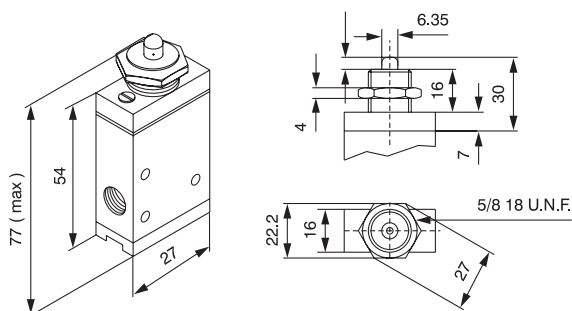

3/2 LOCK DOWN VALVE

(Part No. N 53603L)

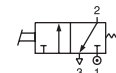

Switching the lever effects valve change over and the valve will remain locked in that position. The spring return will not reset the valve until the lever is reversed.

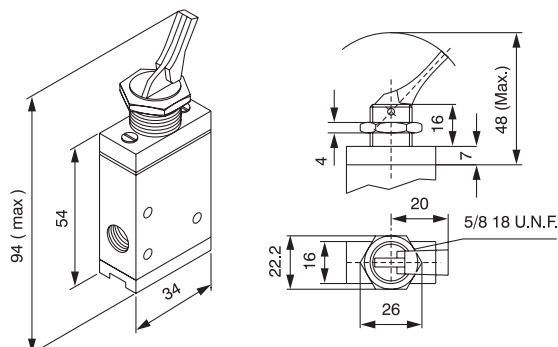

3/2 MUSHROOM BUTTON VALVE
(Part No. N 53603M)

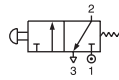

This push button valve is supplied with a threaded neck for panel mounting. Ideal for panel mounting application.

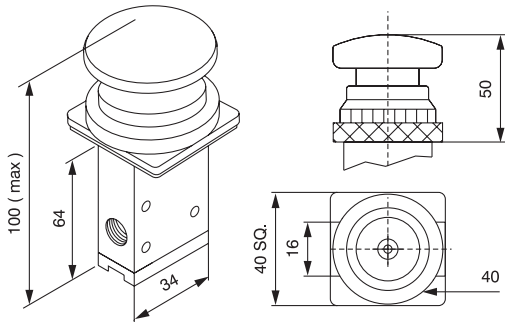

3/2 FLUSH BUTTON VALVE
(Part No. N 53603N)

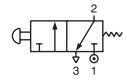

This push button valve is supplied with a threaded neck for panel mounting. Ideal for panel mounting application.

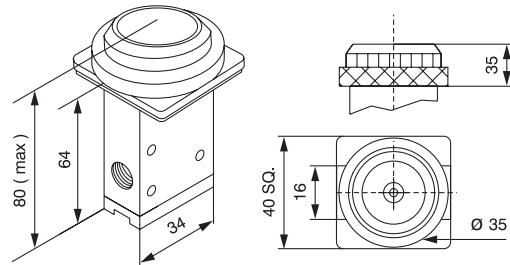

3/2 TEST LEVER VALVE
(Part No. N 53603S)

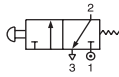

Similar to push button operation, test lever valve is also used for manual actuation of midget single acting cylinders, single acting rotary actuators etc.

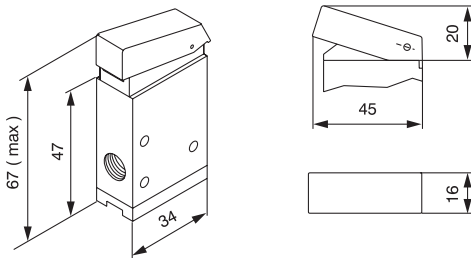

3/2 PILOT OPERATED VALVE
(Part No. N 53603P)

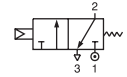

The valve requires an air signal to the pilot port to change the valve over. The valve will remain in that position as long as the signal is held on. Once the signal is exhausted the spring return will return the valve to its original position.
Min. pilot pressure : 0.8 bar at 7 bar inlet.

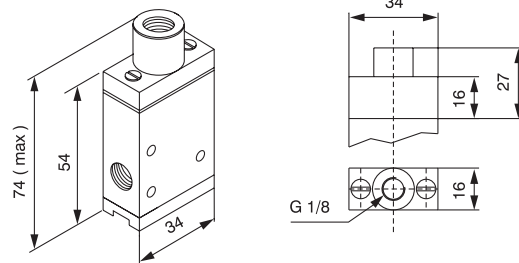

3/2 ONE WAY TRIP LEVER VALVE
(Part No. N 53603T)

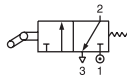

This valve gets actuated and operates only in one direction while the actuation in other direction will just pass over. This is useful in unidirectional signal generation.

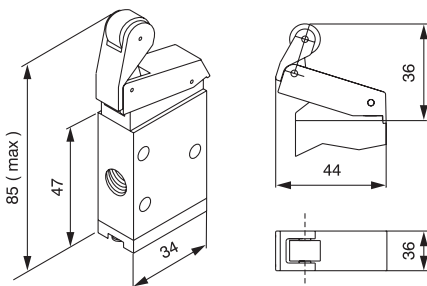

3/2 ROLLER VALVE
(Part No. N 53603R)

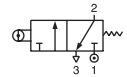

Suitable for mechanical operation by any moving part of the machine. Set the actuation properly to prevent damage of the valve. Max. travel 4.2 mm.

